



NX700 High Efficiency Gas-Fired Condensing Water Heater

Submittal Sheet

Section 1 - Specifications
Section 2 - Dimensions
Section 3 - Electrical

Project Name: _____ Date: _____
 Location: _____
 Engineer: _____
 Contractor: _____ Rep: _____

1 SPECIFICATIONS

General Specifications

- ▶ Product Features
 - Factory set to operate with Natural Gas (**NOTICE: not approved for use with Propane**)
 - Certified to ANSI Z21.10.3 / CSA 4.3 Gas Water Heater Standard
 - ASME "H" stamped, designed and constructed in compliance with the ASME Boiler and Pressure Vessel Code Section IV
 - SA-249 TP316L Stainless Steel Heat Exchanger
 - CSD-1 compliant
 - Maximum operating pressure 160 psi [1103 kPa]
 - Modulating burner, 4.4:1 turndown
 - Direct Spark Ignition
 - Zero clearance to combustibles (clearances required for service)
- ▶ Optional Side Wall Vent Terminal Kits Hubbell part # 84355, 84358
- ▶ Optional Air Filter Kit Hubbell part # 84093 (indoor combustion air only)
- ▶ Factory Supplied Items
 - Flow switch
 - 150PSI ASME Relief Valve
 - 160PSI Pressure Gauge
- ▶ Control Features
 - Integral microprocessor safety control
 - Time of day input
 - Lead-Lag up to 8 series water heaters
 - Integrated Modbus RTU for connection to BMS gateways

Water Connections NPT, in.	Gas Connection NPT, in.	Vent/Air-inlet Pipe Diameter, in.	Vent/Air-inlet Max. Length, ft.	Approx. Weight with Water, lb.
2 (Female)	1 (Male)	Air-inlet 4	100	425
		Vent 6	100	

Performance Specifications

Input Modulation, MBH	Gross Output Capacity, MBH	Thermal Efficiency, %	Recovery Rate @ 100°F Rise, USGPH
160 – 700	672	96	806

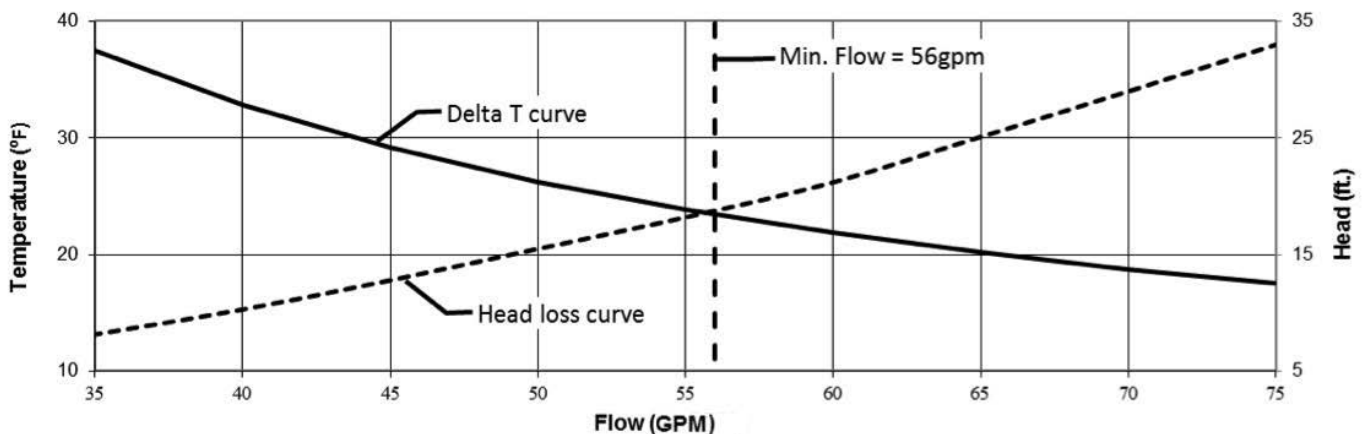

Hubbell Electric Heater Company
P.O. Box 288, Stratford, CT 06615

2016-04-27
Rev.0

Sale: (203) 378-2659 Fax: (203) 378-3596 Web: <http://www.hubbellheaters.com/>
Hubbell Heaters reserves the right to change these specifications without notice

DIMENSIONS

Product Dimensions – in.

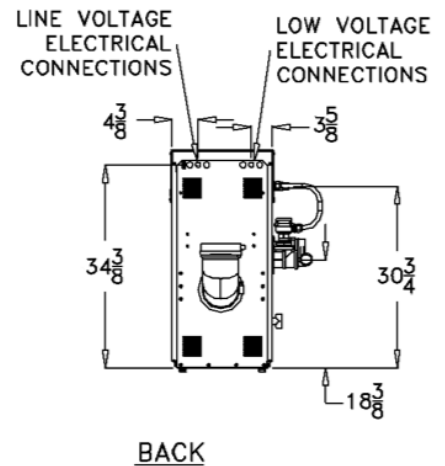
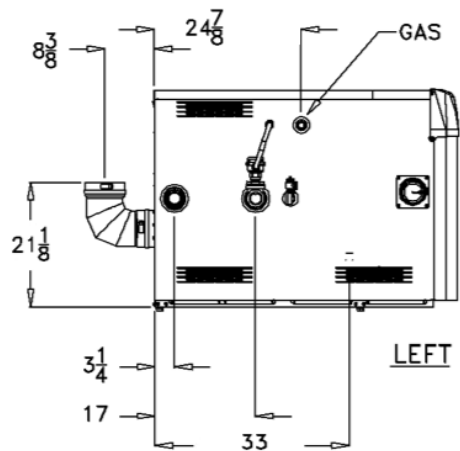
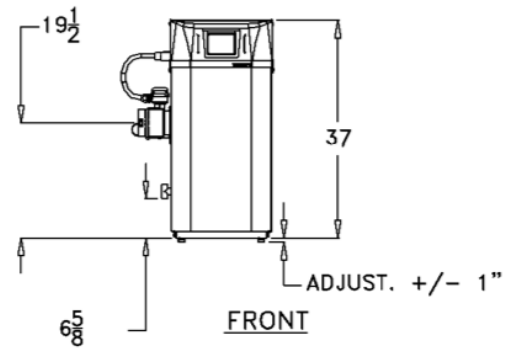
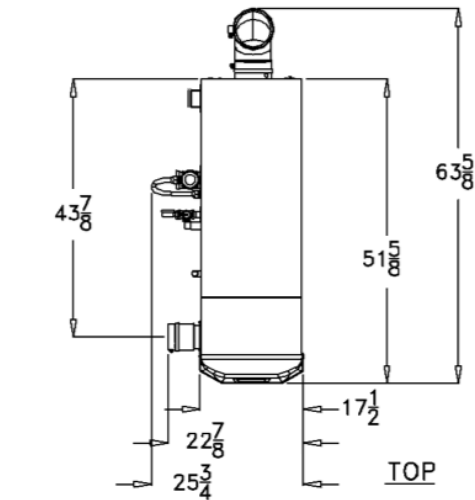

Recommended Clearances – in.

Top	Front	Left	Right	Back	Bottom
24	24	24	12	24	0



Hubbell Electric Heater Company
P.O. Box 288, Stratford, CT 06615

3 ELECTRICAL

Simplified Wiring Diagrams

Line Voltage Electrical:

- ▶ 120VAC / 60 Hz / 1 Phase / 12 Amp
- ▶ Barrier Strip for field wiring terminations
- ▶ Pump output (Pump B)

Note: Pumps are field supplied.

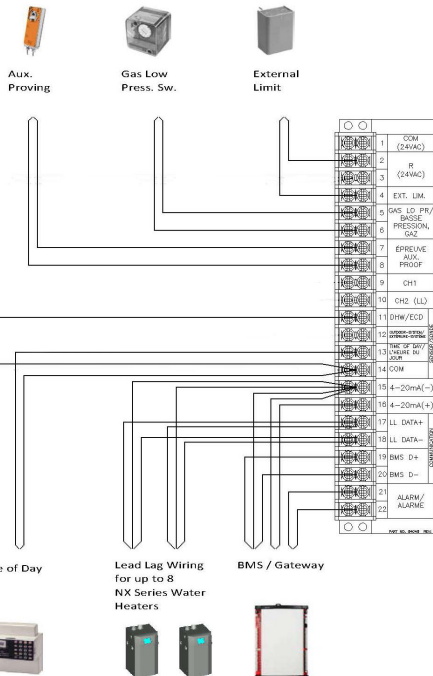
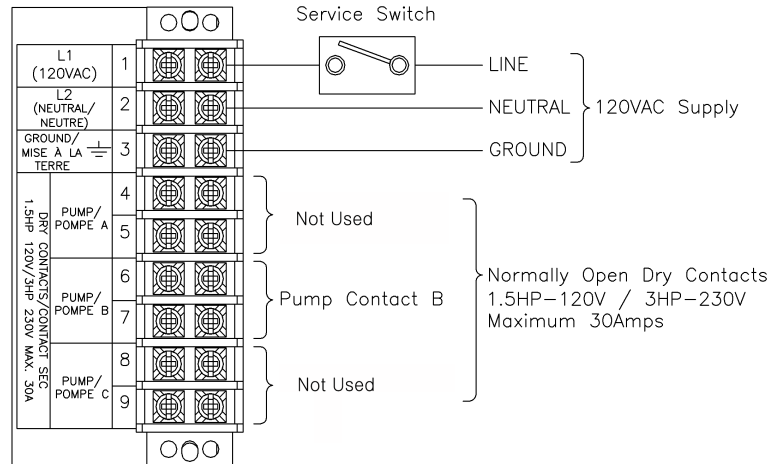

Low Voltage Electrical:

- ▶ Barrier Strip for field wiring terminations
 - ▶ 120/24 VAC Transformer 40VA (factory supplied)
 - ▶ Inputs
 - Indirect DHW aquastat (by others) or DHW Tank sensor (factory option)
 - External Limit (by others)
 - 4-20mA external modulating control (by others)
 - ▶ Outputs
 - Alarm dry contact (24VAC 0.63A max.)
 - ▶ EIA-485 Modbus communications for Lead-Lag
 - ▶ EIA-485 Modbus to BMS gateways (not shown).
- Optional available gateways:
- BACnet/N2- Hubbell part # 84946
 - LonWorks- Hubbell part # 84947



Hubbell Electric Heater Company
P.O. Box 288, Stratford, CT 06615