

**INSTALLATION, OPERATION AND
MAINTENANCE MANUAL FOR
COMMERCIAL INDIRECT
POWERED WATER HEATER**

Hubbell™
ELECTRIC HEATER COMPANY

BASE MODEL “ T ”

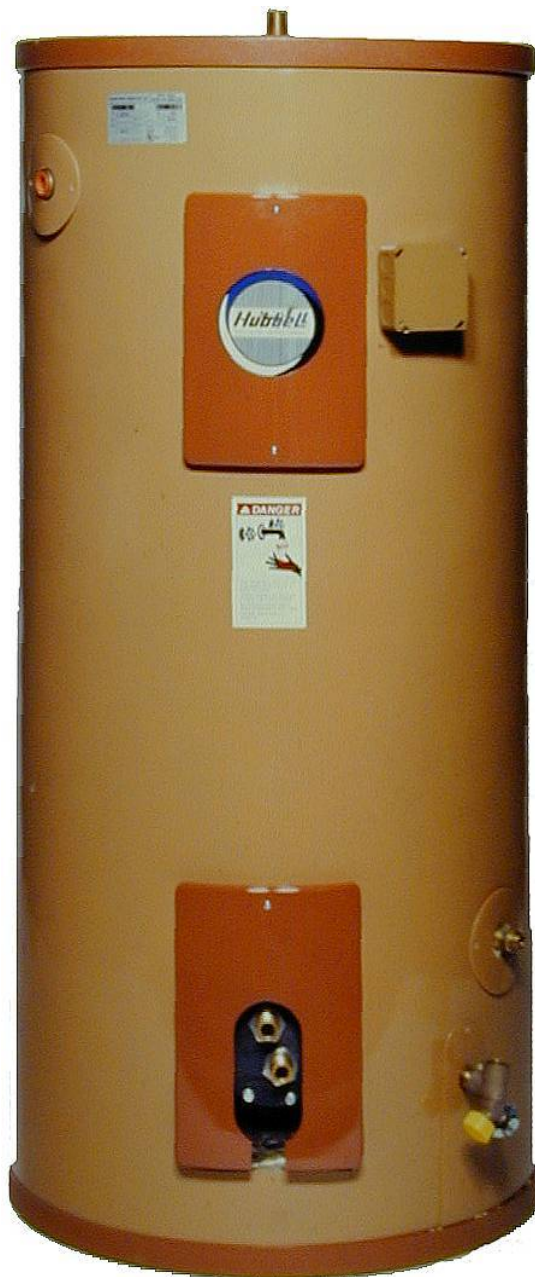

**HUBBELL
ELECTRIC HEATER COMPANY
P.O. BOX 288
STRATFORD, CT 06615**

PHONE: (203) 378-2659

FAX: (203) 378-3593

INTERNET: <http://www.hubbellheaters.com/>

-- IMPORTANT --

Always reference the full model number and serial number when calling the factory.

WARNING / CAUTION

1. Tank is to be completely filled with water and all air is to be vented before energizing.
2. Due to the rigors of transportation, all connections should be checked for tightness before heater is placed in operation.
3. Safety relief valve must be installed in tapping provided.
4. **KEEP AWAY FROM LIVE ELECTRICAL CIRCUITS.**
Do not perform any maintenance, make any adjustments, or replace any components inside the control panel with the high voltage power supply turned on. Under certain circumstances, dangerous potentials may exist even when the power supply is off. To avoid casualties, always turn the power supply safety switch to off, turn the charge or ground the circuit before performing any maintenance or adjustment procedure.
5. The unit is designed to operate at pressure not more than 150 psi.
6. Generalized instructions and procedures cannot anticipate all situations. For this reason, only qualified installers should perform the installations. A qualified installer is a person who has licensed training and a working knowledge of the applicable codes regulation, tools, equipment, and methods necessary for safe installation of an electric resistance water heater. If questions regarding installation arise, check your local plumbing and electrical inspectors for proper procedures and codes. If you cannot obtain the required information, contact the company.

SECTION	TITLE	PAGE No.
I	GENERAL DESCRIPTION AND CONSTRUCTION	4
II	INSTALLATION	6
III	SCHEDULED MAINTENANCE AND OPERATION	8
IV	TROUBLESHOOTING	10
V	SERVICING AND REPLACEMENT OF PARTS	11
VI	MISCELANEOUS CHARTS AND FORMULAS	19

OUTLINE DIMENSIONS

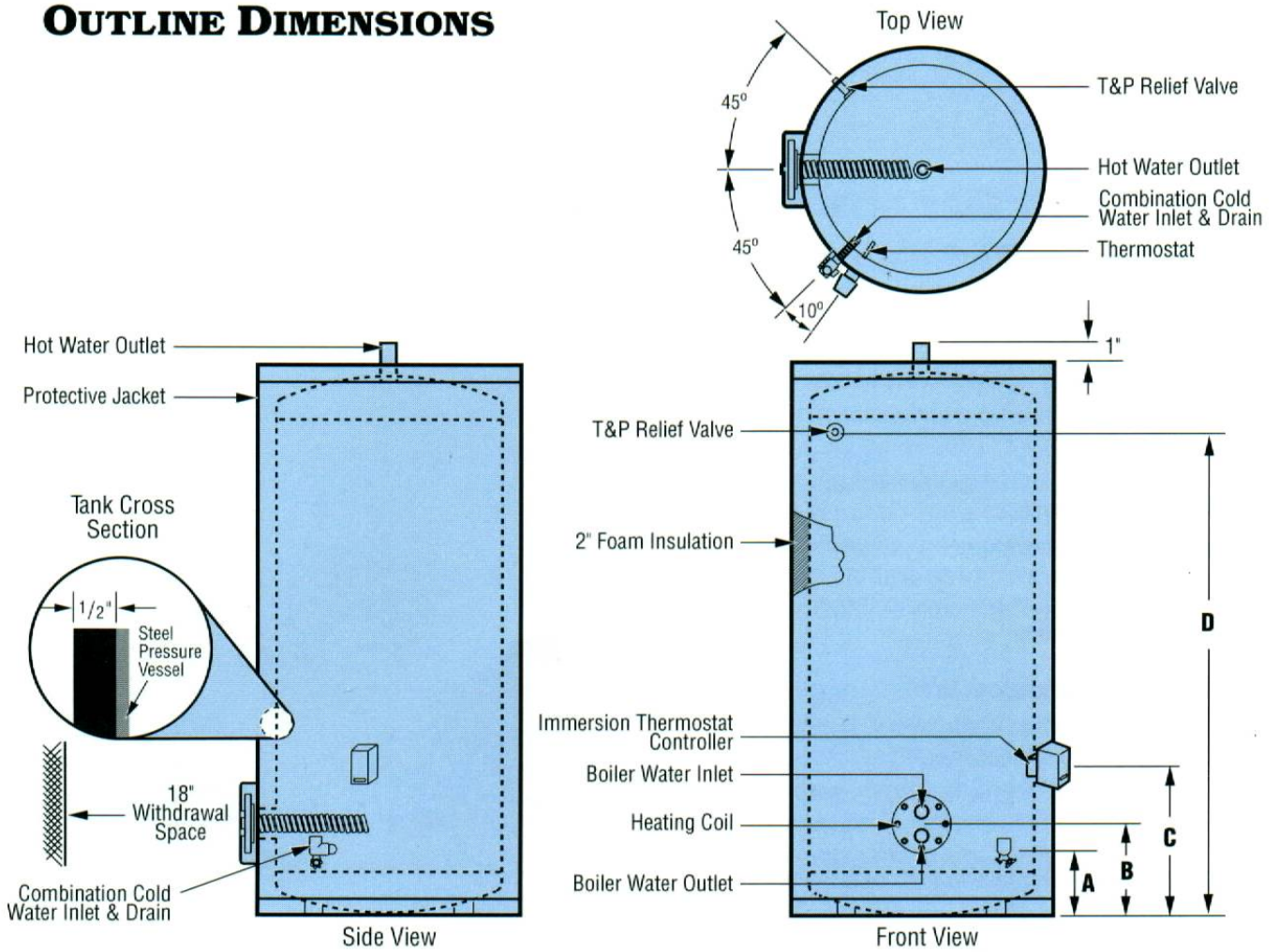

Base Model	Storage Capacity (Gallons)	Heating Coil Size (Sq Ft)	First Hour Rating * (Gallons)	Dimensions (Inches)						Inlet / Outlet Size (Inches)	Shipping Weight (lbs.)
				Overall Diameter	Overall Height	Inlet "A"	Coil "B"	Thermostat "C"	T&P Valve "D"		
T30-15	30	15	128	20	40.5	7	10	13	34	3/4	180
T40-15	40	15	139	20	58.75	7	10	13	51	3/4	230
T65-20	65	20	165	26	48	8	10	14	40	3/4	310
T80-20	80	20	182	26	58	8	10	14	51	3/4	340
T120-20	120	20	188	28	69.25	8	11	17	62	3/4	420
T120-40	120	(2) 20	306	28	69.25	8	11	17	62	1 1/2	435
TU40-20	40	20	152	26	33	7	8	14	24	3/4	235

* First hour ratings based on a 80°F rise (40-120°F) when supplied with 6 GPM of 200°F boiler water.

SECTION I - GENERAL DESCRIPTION AND CONSTRUCTION

GENERAL DESCRIPTION

This book describes a packaged boiler water powered indirect water heater that is a stationary, self-contained unit. The complete assembly on a standard unit consists of the storage tank, immersion heating coil, and an ASME rated combination temperature and pressure safety relief valve. Optional equipment may be supplied with your unit. Please consult the product drawing for details specific to your assembly. The unit is factory assembled, insulated, jacketed, wired, tested, and ready for electrical and plumbing service connections.

CONSTRUCTION

TANK

The standard storage tank is constructed of steel and internally lined with specially formulated Hydrastone cement to a ½-inch minimum thickness. The tank is designed for a maximum allowable working pressure of 150 psi (300 psi TP).

TANK CONNECTIONS

The heater is supplied with separate cold water and hot water connections. Water entering the cold water inlet is deflected by means of a baffle within the tank. The hot water outlet includes a built in heat trap to prevent hot water from radiating out from the heater. A ¾-inch FNPT connection is located on the side of the heater for mounting a combination safety temperature and pressure relief valve. An overflow line should be installed from the relief valve outlet to a floor drain. A ¾-inch GHT connection is supplied for draining. See drawing for locations and sizes.

OUTER SHELL AND INSULATION

The tank is encapsulated in 2-inch thick polyurethane foam insulation. The insulation is protected by a high impact non-corroding colorized composite protective jacket.

HEATING COIL

The water heater is supplied with a high quality, factory installed, high efficiency, single walled, copper finned heating coil designed for a maximum working pressure of 150 psi. The tubing is installed in a heavy-duty fabricated steel head with threaded NPT connections. Each assembly is fastened to a corresponding tank flange using a gasket and hex head steel bolts and nuts.



CONTROL THERMOSTAT

The water heater is supplied with an immersion thermostatic switch. The thermostat can be adjusted through a range of 120° - 140° F.



OPTIONAL BACK-UP ELECTRIC HEATING SYSTEM

Back-up Electric Heating Element

The water heater may be supplied with an electric immersion heating element assembly(s). Each assembly is fastened to a corresponding tank flange using a gasket and four (4) 3/8-16 x 1-inch long hex head steel bolts and nuts. See drawing for voltage and power ratings.



Control Thermostat

The water heater may be supplied with either a surface mounted or immersion thermostatic switch to control the back-up electric heating system. See drawing for specific details. The surface mounted thermostat can be adjusted through a range of 110° - 170° F. The immersion thermostat can be adjusted through a range of 100° - 190° F. Both thermostats are adjustable with a flat tip screwdriver.



Surface Mounted Thermostat



Immersion Thermostat

Temperature High Limit Switch

As a safety device, either a surface mounted high temperature cut-off switch with manual reset, factory set at 190° F, or an immersion high temperature cut-off switch with manual reset, factory set at 180° F, may be provided. In the event of an over-temperature condition, the thermostat will disengage the power from the back-up electric heating system. The high limit must be manually reset thereafter to restart the heater.

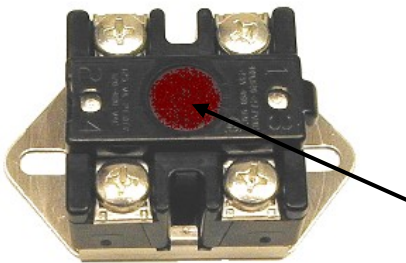

Manual

Surface Mounted High Temperature Cut-Off Switch



Reset

Immersion High Temperature Cut-Off Switch

Double Wall Heating Coil

A Double Wall Heat Exchanger consists of two copper tubes, one inside the other, wound into a coil. The outer tube is soldered into the fitting that mates into the tank. The inner tube is soldered into the fitting that mates with the hot water supply. The gap between the two tubes is open to the air, allowing visible detection of any leaks, as well as preventing any leaks from mixing into the other liquid.

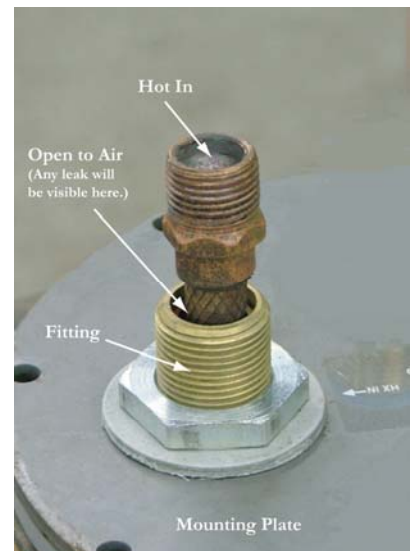

SECTION II – INSTALLATION

WARNING / CAUTION

DO NOT TURN ON THE BOILER WATER SUPPLY to this equipment until heater is completely filled with water and all air has been released. *If the heater is NOT filled with water when the power is turned on, damage to the heating coil may result.*

For protection against excessive pressures and temperatures, local codes require the installation of a temperature-and-pressure (T&P) relief valve certified by a nationally recognized laboratory that maintains periodic inspection of production of listed equipment of materials, as meeting the requirements for Relief Valves and Automatic Gas Shutoff for Hot Water Supply Systems. ANSI Z21.22-1971. THE CUSTOMER IS RESPONSIBLE TO PROTECT PROPERTY AND PERSONNEL FROM HARM WHEN THE VALVE FUNCTIONS.

All water heaters have a risk of leakage at some unpredictable time. IT IS THE CUSTOMER'S RESPONSIBILITY TO PROVIDE A CATCH PAN OR OTHER ADEQUATE MEANS, SO THAT THE RESULTANT FLOW OF WATER WILL NOT DAMAGE FURNISHINGS OR PROPERTY.

WATER HEATER PLACEMENT

1. Place the heater on a solid foundation in a clean, dry location nearest to the point of most frequent hot water use. If the heater is to be raised off the floor, the entire bottom of the heater should be supported by a solid surface.
2. The water heater should be protected from freezing and waterlines insulated to reduce energy and water waste.
3. Leave a minimum of 18" clearance for element withdrawal, if necessary.

INSTALL THE HEAT EXCHANGER COIL

1. Remove the access panel.
2. Apply the included o-ring lubricant to o-rings.
3. Insert the o-rings into the grooves on the plastic o-ring housing.
4. Insert heat exchanger and align holes in cover plate with holes in flange.
5. **WARNING: Plastic o-ring housing must be properly installed. Failure to do this will void the warranty.**
6. Insert and secure the bolts to the nuts one at a time in the following manner:
 - Place the nut behind the flange opening.
 - Hold the nut in place with one hand – insert the bolt with washer with the other.
 - Thread the bolt through the washer and into the nut and tighten.
 - **NOTE: Be sure to place bolts in all of the openings.**

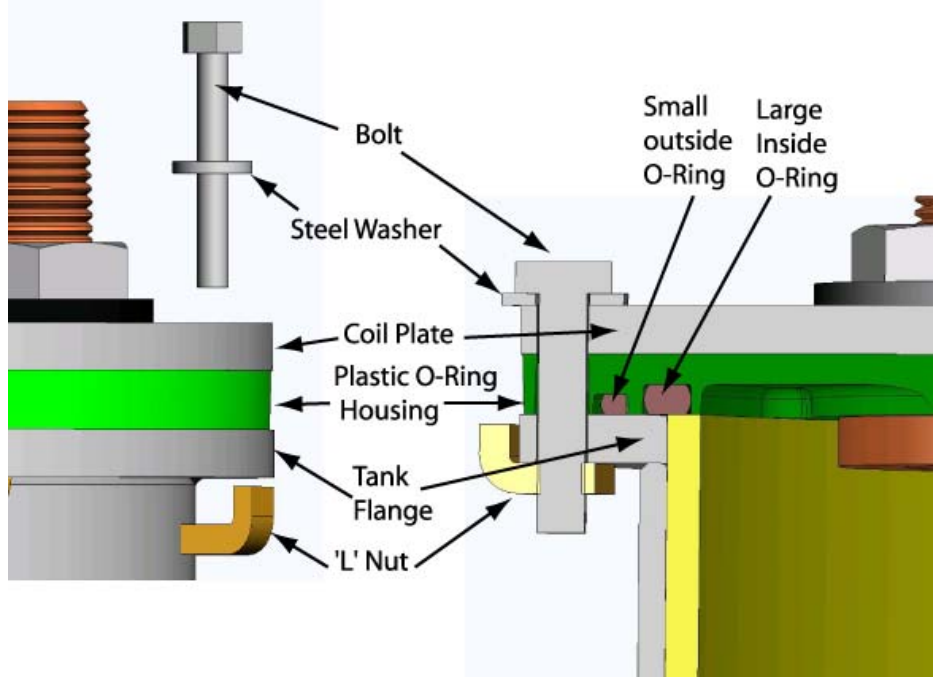

Proper tightening sequence for coil

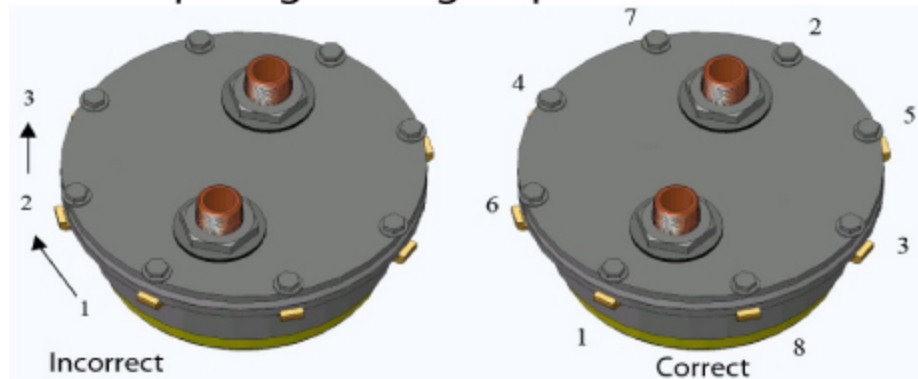

Note:- Same as car tire lugs

Caution: Does not require excessive force to seal properly.

PIPING INSTALLATION

NOTE: The most effective means for preventing deterioration from accelerated corrosion due to galvanic and stray current is the installation of dielectric fittings/unions. The installation of these fittings is the responsibility of the installing contractor.

1. All integral components have been properly sized to meet design conditions. Piping to the unit should be sized to meet the design conditions, as dictated by good engineering practices.
2. Connect boiler water supply and return lines to heating coil assembly. Connect the cold water inlet and hot water outlet to the appropriate connections as shown; refer to the drawing for location and sizes.
3. Install the combination temperature and pressure safety relief valve in the tapping provided. Note that this is required by law for safety considerations.

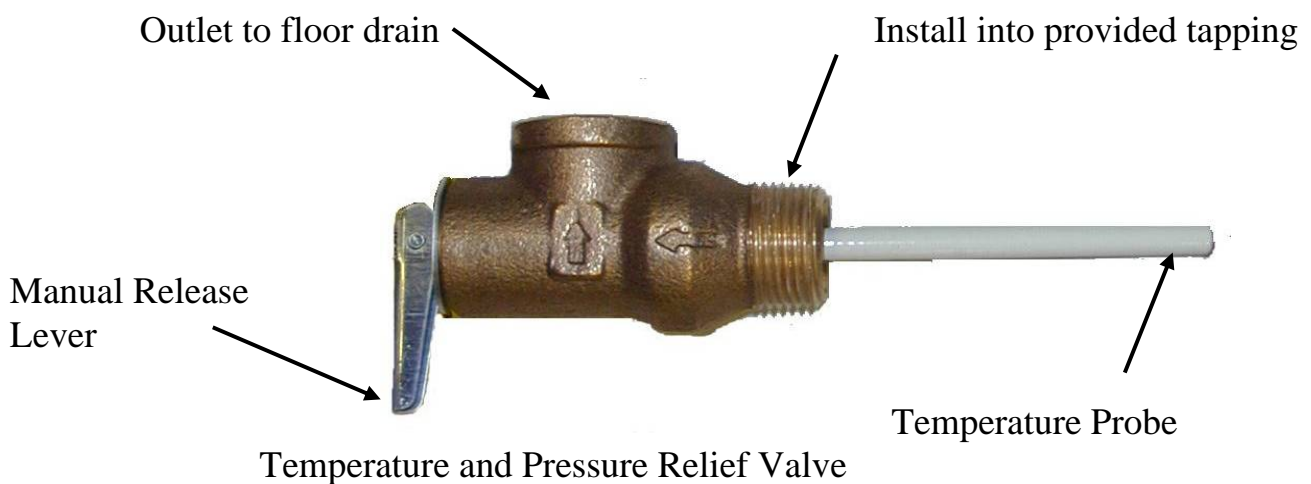

4. Install a relief valve overflow pipe to a nearby floor drain. **CAUTION:** No valve of any type should be installed between the relief valve and tank or in the drain line.

TRANSFLOW MODEL TYPICAL INSTALLATION

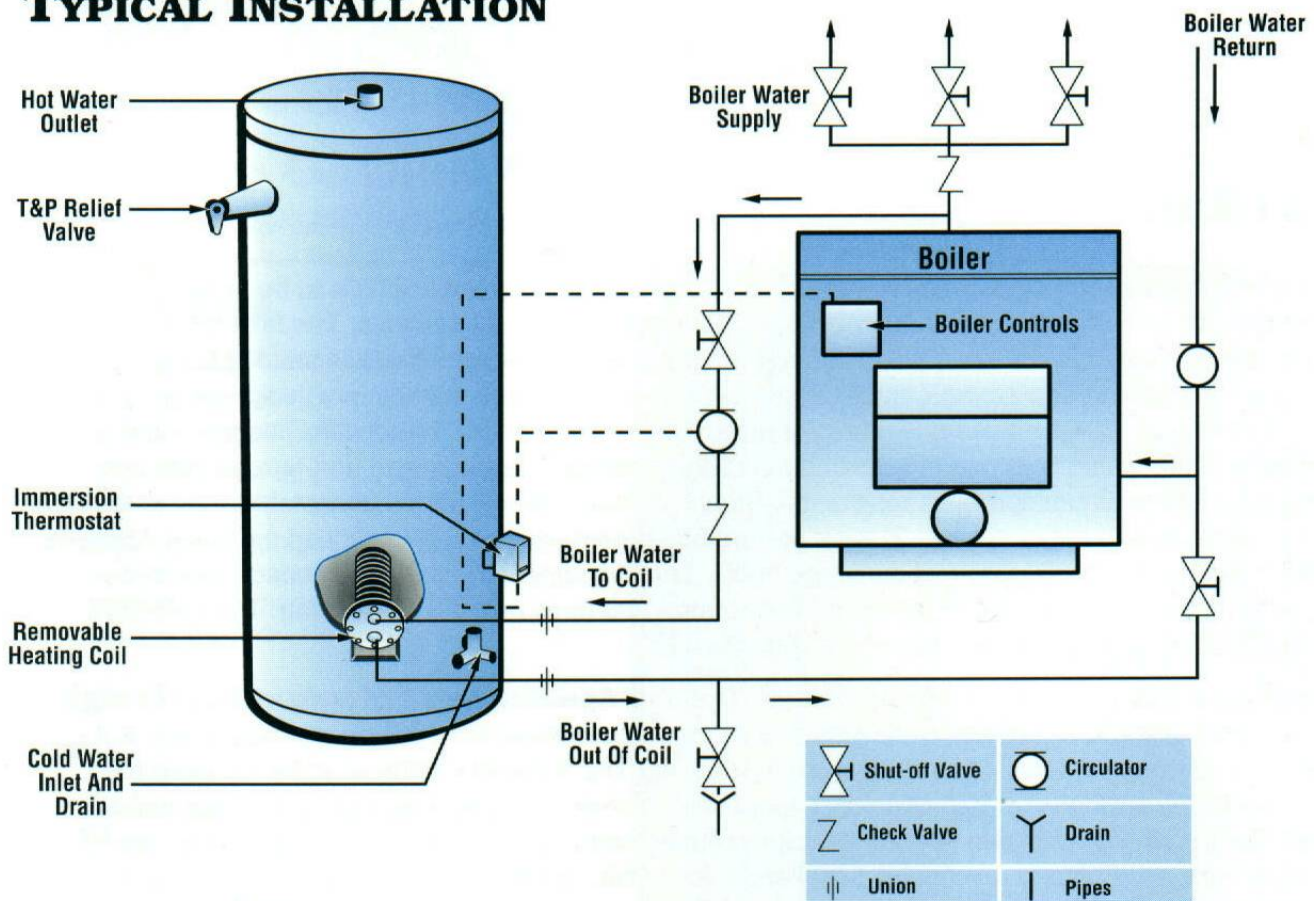

ELECTRICAL INSTALLATION

1. Connect electrical wiring from boiler controls and circulator pump to immersion thermostat.
2. If supplied with a back-up electric heating element; enter electric enclosure with properly sized feeder leads. Be sure to properly ground the water heater. Install these power leads into the box lugs on the terminal block.
3. Torque screws per torque chart included in Section VI.
4. All other electrical connections are made at the factory; therefore, no other electrical connections are necessary.

FILLING THE HEATER

1. Completely close the drain valve.
2. Open the highest hot water faucet to allow all air to escape from piping.
3. Open the valve to the cold water inlet and allow the heater and piping system to completely fill, as indicated by a steady flow of water from the open faucet.

FINAL CHECKS

1. Check all connections for tightness.
2. Ensure that all the above steps are completed
3. After the water is heated for the first time, monitor the water temperature as described in Section III, Quarterly Inspection.

SECTION III - SCHEDULED MAINTENANCE AND OPERATION

WARNING / CAUTION

Before performing any maintenance procedure, make certain boiler water and electric supply is OFF and cannot accidentally be turned on.

MAINTENANCE AND OPERATION

The water heater is automatic in its operation. It will maintain a full tank of water at the temperature setting of the thermostat. The water heater should not be turned on without first making sure that the tank is full of water and that all air has been released.

FREEZING

The tank should be fully drained in the event the boiler water has been turned off and if there is danger of freezing.

QUARTERLY INSPECTION

1. Monitor thermostat
 - a. Let water heater completely heat to a designated thermostat setting.
 - b. After thermostat satisfies (that is, when the thermostat actually clicks off), draw water from heater.
 - c. Compare water temperature of drawn water to the temperature setting of the thermostat when it satisfies. Normal variation between the two points is approximately $\pm 5^{\circ}\text{F}$.
 - d. If these two readings do not coincide within acceptable tolerances and verification has been made of the accuracy of the temperature-reading gauge, replace the thermostat.
2. Lift test lever on relief valve and let water run through valve for a period of approximately 10 seconds. This will help flush away any sediment that might build up in water passageways.
3. Inspect heating coil flange for leakage as follows:
 - a. Remove heating coil housing cover.
 - b. Visually inspect heating coil gasket for evidence of leaks.
 - c. Rub finger around gasket that is between the heating coil and tank flange for any evidence of moisture. If moisture is present or a water drip is observed, follow procedure outlined in Section V.
4. Check for loose electrical connections. Tighten as necessary.

ANNUAL INSPECTION

1. Flush tank as follows
 - a. Shut off power supply.
 - b. Close valve on hot water outlet piping.
 - c. Open valve on drain piping.
 - d. Cold water inlet line pressure will be strong enough to flush sediment from the bottom of the tank out through the drain. Let water run for 3-4 minutes.
 - e. Close drain valve.
 - f. Open hot water valve.
 - g. Turn power supply ON.
2. Units subject to fouling or scaling should be cleaned periodically. A marked increase in pressure drop and/or a reduction in performance usually indicates cleaning is necessary.
3. To clean inside of tubes, remove all heads and covers. (**Caution: Do not loosen heads until you are sure all pressure is off the equipment, and the unit is drained**). Clean the unit using the following methods.
 - a. Circulate hot fresh water at a reasonable velocity.
 - b. Try spraying with water hose.
 - c. Consult with manufacturers of cleaning compounds and chemicals. They will check the nature of the deposit, recommend the right cleaning compound, and in many cases provide equipment and personnel for a complete cleaning job.
4. If the unit is dismantled for any reason, it should be reassembled using new gaskets.
5. Do not tighten bolts until gaskets are properly seated.
6. When tightening bolts in the element head, tighten the bolts in a criss-cross pattern. This will evenly distribute pressure around the flange, and help prevent warping.

SECTION IV – TROUBLESHOOTING

Symptom	Probable Cause	Corrective Action / Remedy
Gradual loss of heating capacity.	Tubes are fouled.	Clean tubes per Section III, annual scheduled maintenance.
	Excess silt in bottom of tank.	Drain and flush tank per Section III , annual scheduled maintenance.
Overheating.	Ruptured tube(s) in heating coil.	Remove / replace heating coil.
	Thermostat needs adjusting.	Adjust thermostat
	Circulator not operating.	Repair or replace per separate O&M.
Immediate loss of heating capacity.	Blockage in return line.	Clean blockage from return line.
Excessive vibration.	High rate of flow beyond design conditions.	Consult factory.
	Under sized piping to the unit.	Re-pipe lines to unit using proper sized lines.
Water hammer.	Undersized return lines.	Re-pipe return line using proper sized lines.
	Insufficient slope on return lines causing backup.	Increase slope on return lines.

* **Red symptom** indicates that equipment should be shut down immediately and cause of malfunction corrected before unit is re-started or serious damage may result.

BACK-UP ELECTRICAL HEATER SYSTEM (if supplied)

Symptom	Probable Cause	Corrective Action / Remedy
No hot water	Circuit breaker tripped at source.	Reset circuit breaker.
	High limit switch tripped.	Reset high limit switch.
	Loose wires.	Tighten wires. Torque screws per torque chart included in Section VI.
	Heating element inoperable.	Check heating element operation by clamping an Amprobe around each wire to the element. The ampere reading should agree with the nameplate 'AMP' figure.
	Low line voltage.	Have source electrical system checked by an electrician.
	Faulty thermostat.	Move thermostat dial through full range. A definite 'click' should be heard. If not, replace thermostat.

Water temperature below settings at all times	Faulty thermostat.	Check thermostat adjustment. Monitor thermostat as described in Section III, Quarterly Inspection. Replace if necessary.
	Heating element not working on all phases	Check to see that heating element is working on all phases, by checking the resistance (ohms) value for each element and comparing with expected rating.
	Heater improperly sized	Verify heater is properly sized for the flow rate and temperature rise of your system. Replace elements with proper size as necessary.
Relief valve discharges continuously	Excessive temperature or pressure in tank	Temperature and pressure relief valves are made to operate if the water temperature exceeds 210°F or water pressure exceeds the pressure rating of the safety relief valve. If trouble is excessive temperature, then thermostat is not shutting off at the right setting and thermostat must be replaced.

SECTION V - SERVICING & REPLACEMENT OF PARTS

WARNING / CAUTION

Before servicing or replacing any part make sure to turn the power supply switch to the OFF position.

RELIEF VALVE

1. Disconnect power from unit.
2. Shut off incoming water and boiler water supply.
3. Lift test lever on relief valve to relieve pressure in tank.
4. Disconnect overflow piping.
5. Unscrew relief valve, remove assembly and replace with new one.
6. Connect overflow piping.
7. Turn on incoming water supply and check for leaks.
8. Turn safety switch to ON position.

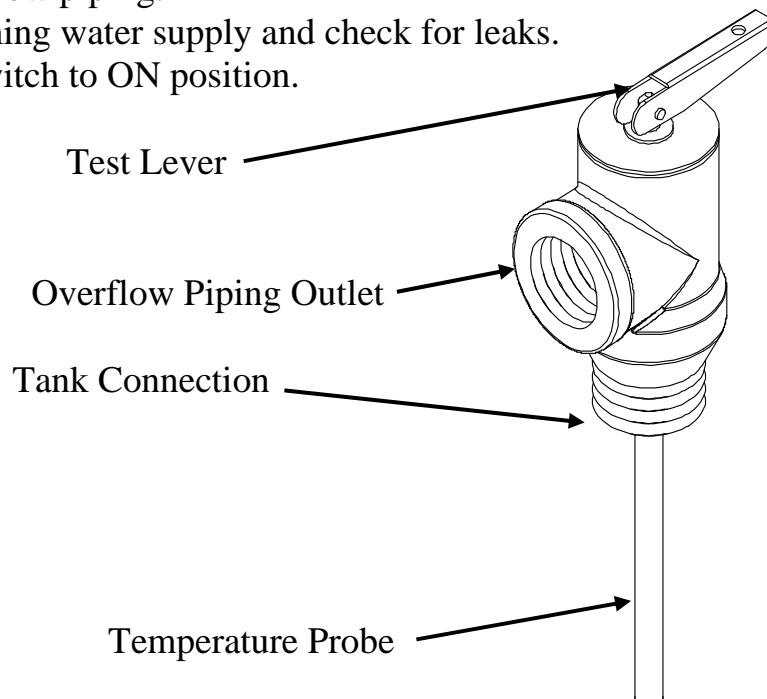

HEATING COIL

1. Disconnect power from unit.
2. Shut off incoming cold and boiler water supply.
3. Attach hose to drain connection.
4. Lift manual release lever on relief valve to let air into system or break union on outgoing water line.
5. Drain water from tank.
6. Disconnect supply and return lines from heating coil.
7. Remove bolts securing the heating coil to the tank flange.
8. Withdraw heating coil assembly.
9. Before installing new heat exchanger it is imperative that the edge of the steel pipe is clean from rust and not damaged. A file may be used to dress up the surface.
10. Install new heating coil assembly, make piping connections, and fill the tank as shown in section II.
11. Check around gasket for any leaks.

SURFACE TEMPERATURE HIGH LIMIT CUT-OFF (if supplied)

1. Disconnect power from unit.
2. Remove access cover.
3. Disconnect the four (4) 14 gauge wires or three (3) 14 gauge wires and a jumper, as required.

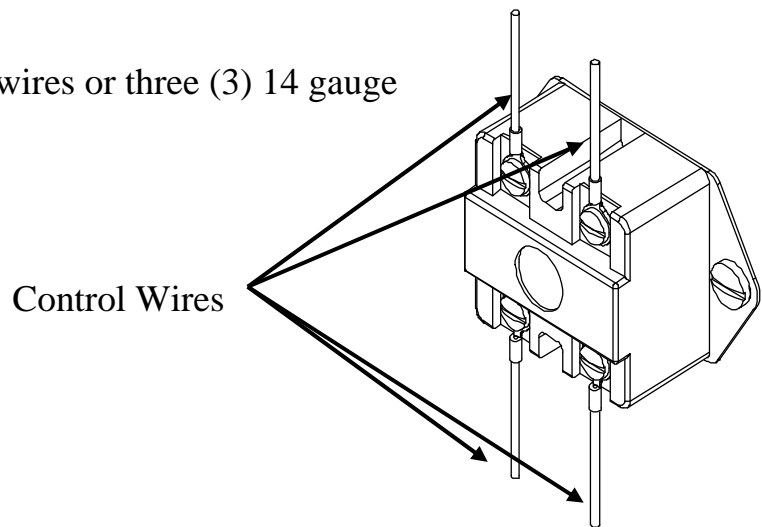

4. Remove the two (2) mounting screws or disconnect from thermostat, as required.

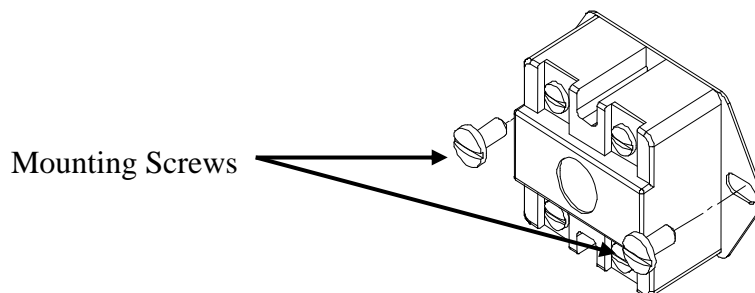

5. Replace control and install new high limit switch by performing above steps in reverse order.

IMMERSION TEMPERATURE HIGH LIMIT CUT-OFF (if supplied)

1. Disconnect power from unit.
2. Remove access cover.
3. Remove high limit cover screw and cover.

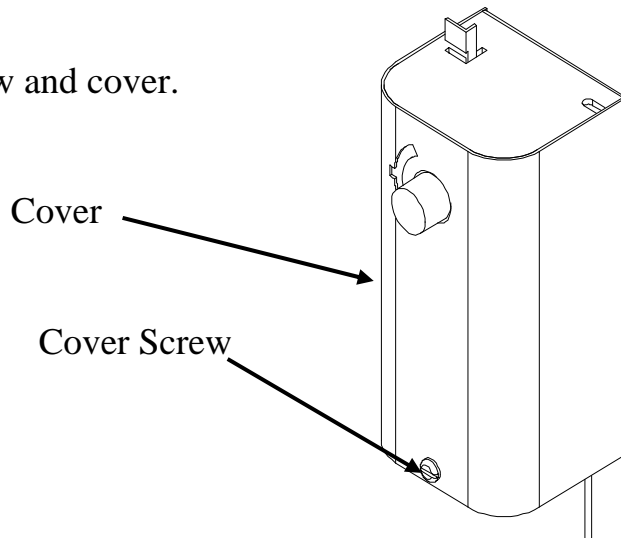

4. Disconnect the two (2) 14 gauge wires.

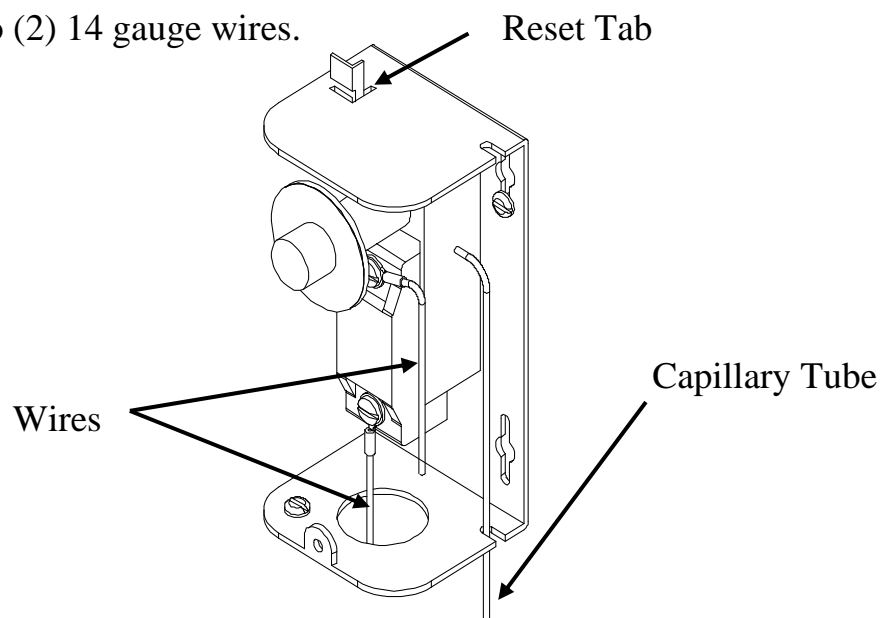

5. Remove capillary tube and bulb from thermowell
6. Remove two (2) mounting screws.

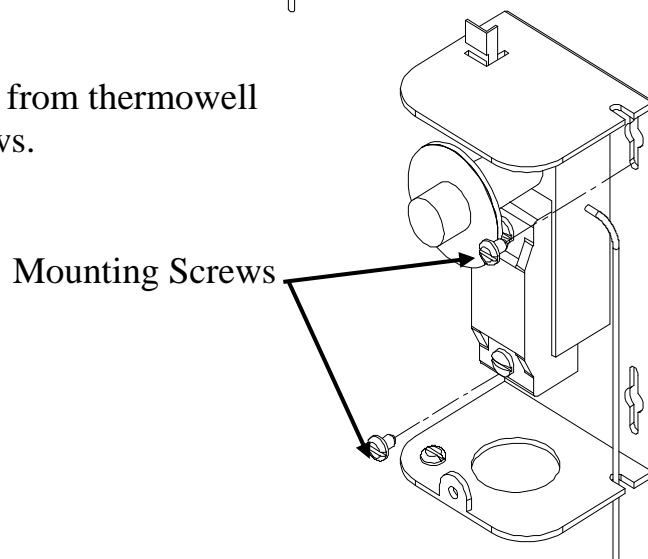

7. Remove control and install new high limit switch by performing above steps in reverse order. (Note: Be sure to place capillary tube into slot in base prior to installing cover.)

HEATING ELEMENT (if supplied)

1. Disconnect power from unit.
2. Shut off incoming water supply.
3. Attach hose to drain connection.
4. Lift manual release lever on relief valve to let air into system or break union on outgoing water line.
5. Drain water from tank.
6. Disconnect the wires from the heating element terminals.

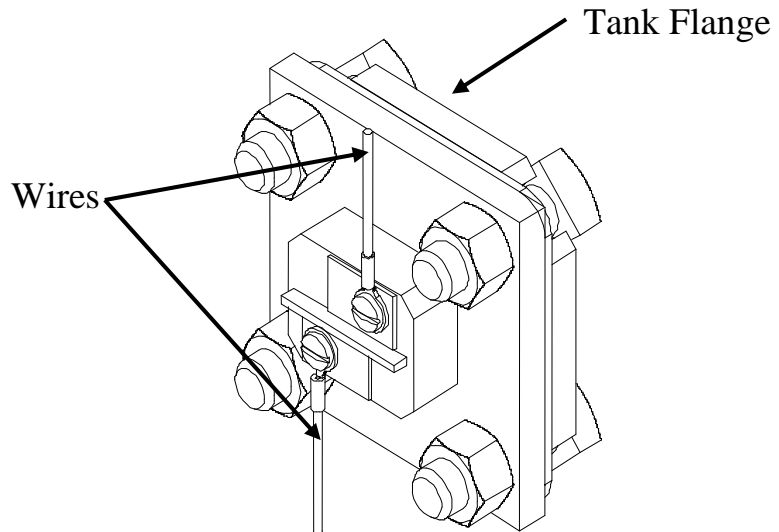

7. Remove the 3/8-16 nuts.
8. Withdraw element assembly and remove gasket.

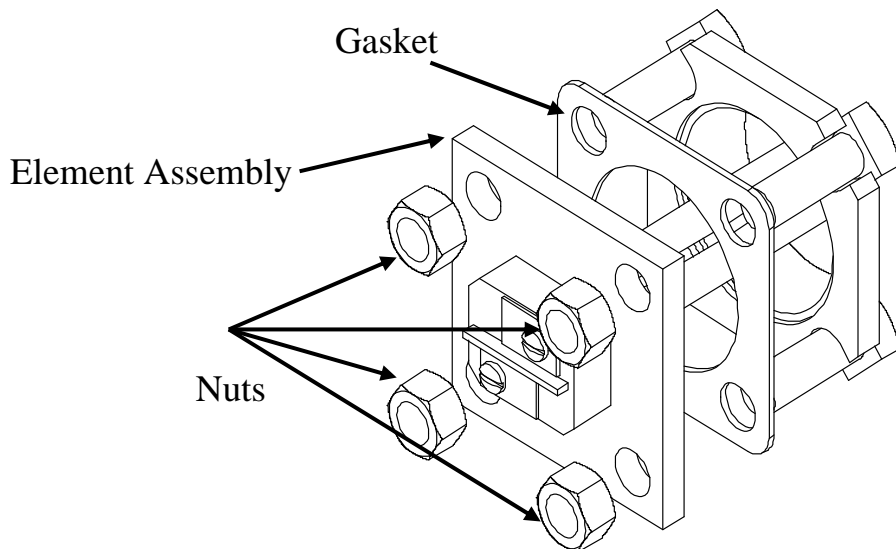

9. Install new gasket and insert new heating element.
10. Rewire element according to type of unit as shown below.
11. Fill tank and check around gasket for any leaks.

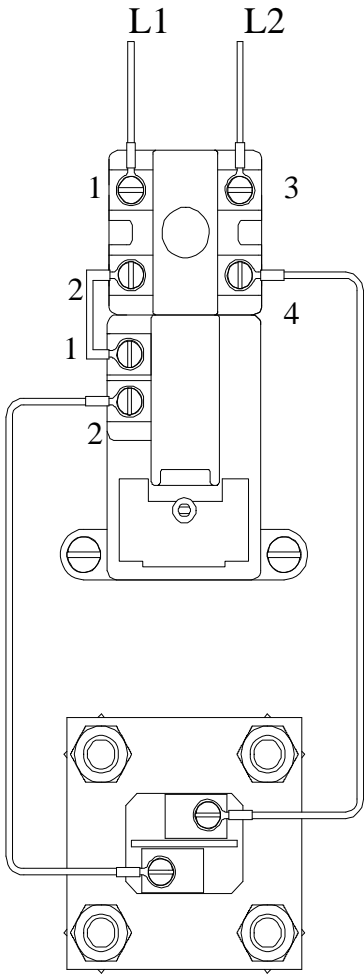

Single Element Operation

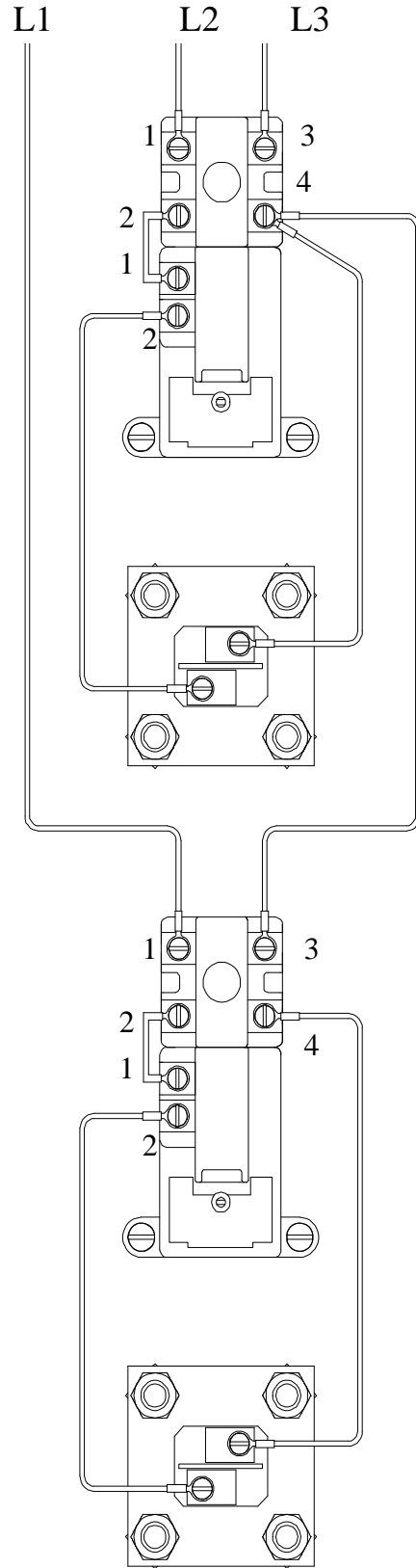

3 Ø Open Delta Wiring for Simultaneous Operation

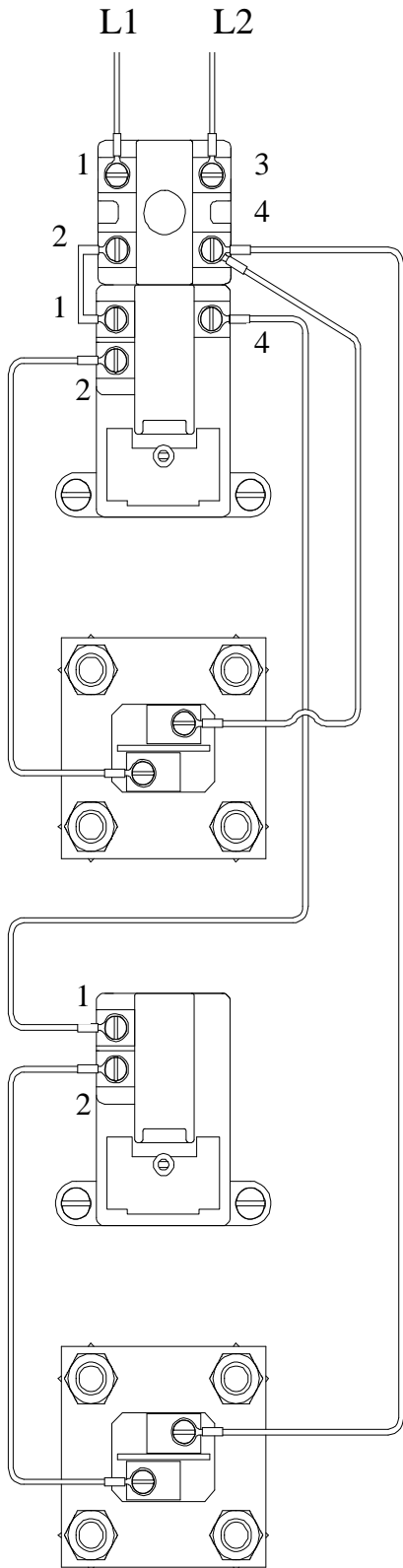

Interlocked for
Non-Simultaneous Operation

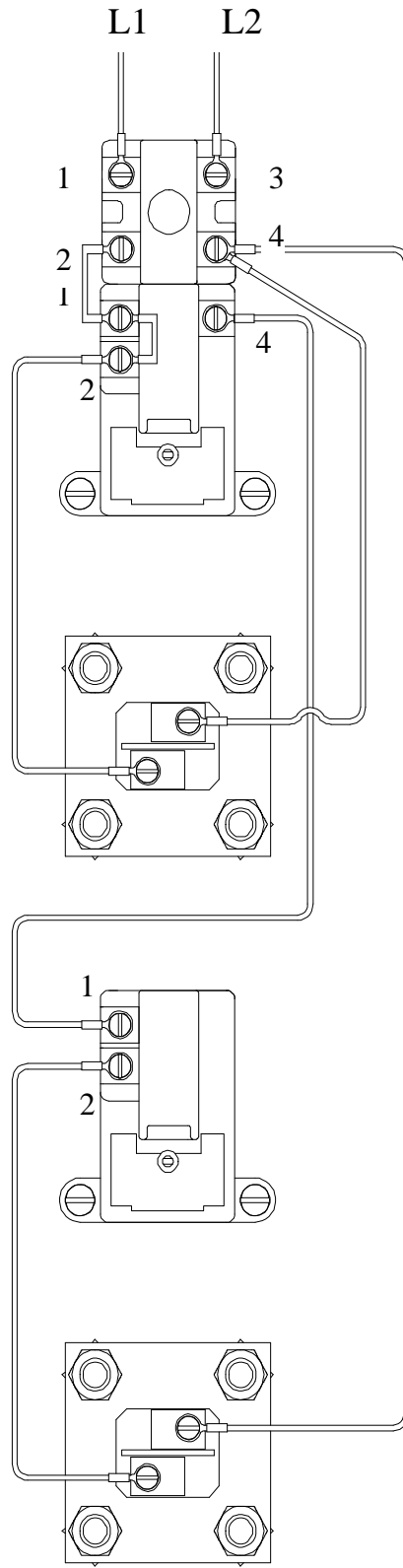

Non-Interlocked for
Simultaneous Operation

SURFACE MOUNTED THERMOSTAT (if supplied)

1. Disconnect power from unit.
2. Remove access cover and locate thermostat.
3. Disconnect the two (2) or three (3) 14 gauge wires and jumpers, as required.

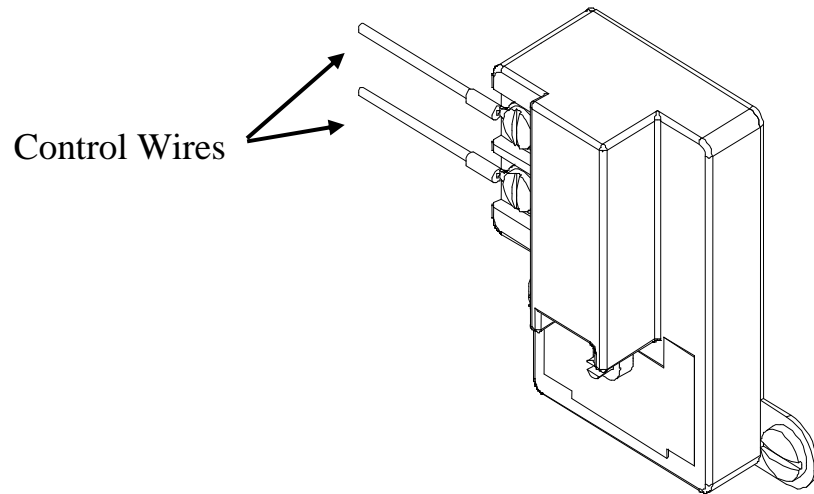

4. Remove two (2) mounting screws and disconnect from high limit cut-off, if required.

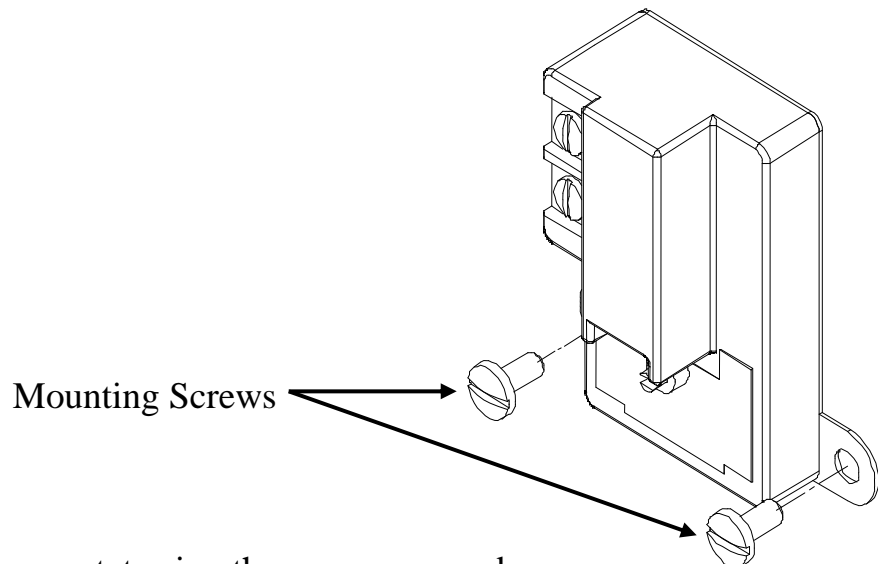

5. Replace thermostat using the reverse procedure.

IMMERSION THERMOSTAT (if supplied)

1. Disconnect power from unit.
2. Remove access cover and locate thermostat.
3. Remove high limit cover screw and cover.

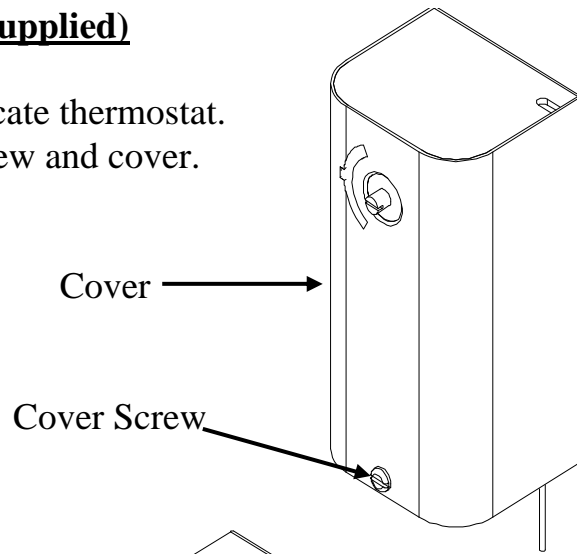

4. Disconnect the two (2) or three (3) 14 gauge wires, as required.

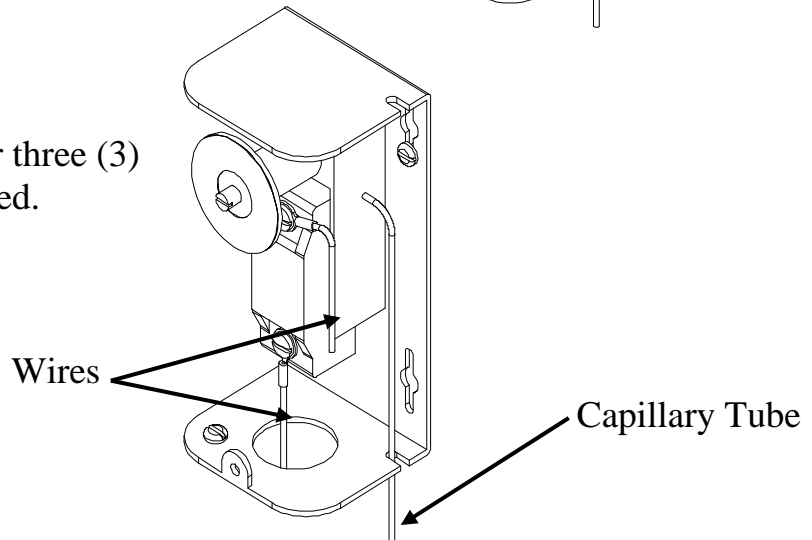

5. Remove capillary tube and bulb from thermowell.
6. Remove two (2) mounting screws.

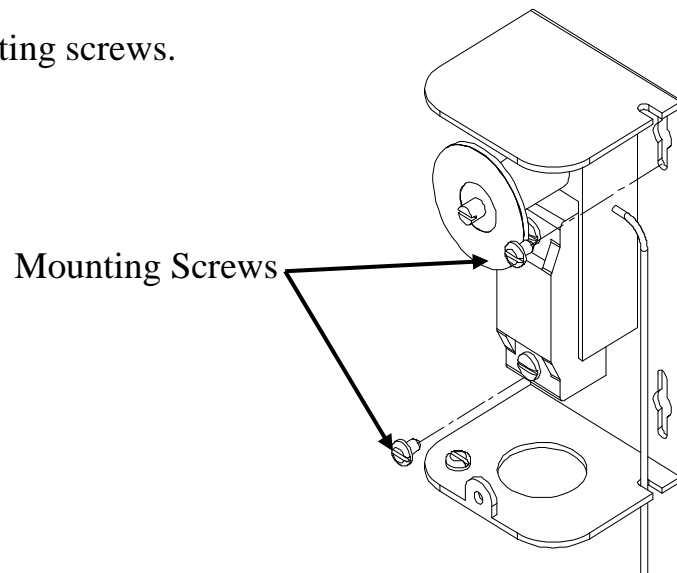

7. Replace thermostat using reverse procedure. (Note: Be sure to place capillary tube into slot in base prior to installing cover.)



P.O. BOX 288
STRATFORD, CT 06615-0288
PHONE: (203) 378-2659
FAX: (203) 378-3593
INTERNET: <http://www.hubbellheaters.com/>